

PowerGuard Owners/Installation manual – Engine start model

READ THE ENTIRE MANUAL BEFORE INSTALLATION

PowerGuard ensures your vehicle engine will always start by shutting off the entire electrical system in the event that the battery voltage falls below a level deemed to be that which will prevent reliable starting. This level is dependent upon the time during which the voltage is low and the ambient temperature.

The reset switch incorporates an integral green LED. In normal mode (“standby”) this LED will be unlit. When the LED starts to blink this indicates the unit has entered the “shutdown imminent” mode and the system will be disconnected 4 minutes later if the battery voltage does not return to normal. Once PowerGuard has disconnected the system, the LED will be on solid (“shutdown”).

Once shut down, the only way to reconnect the system is by pressing the PowerGuard Reset switch.

PowerGuard incorporates an inhibit input (marked “ALT” on the PCB). This input will prevent the unit shutting the electrical system down if a 12 volt feed is provided to it. This could be connected to a feed from the ignition switch that is live when the ignition switch is in the “run” position or it could be connected to the charge warning light terminal on the alternator. The purpose of this is to prevent the unit shutting the electrical system down whilst the engine is running.

WARNING Under no circumstances must this input be provided with a permanent 12 volt feed.

Certain loads require a permanent power feed in order to function and therefore PowerGuard incorporates a “bypass” output which remains connected to the battery even after shutdown. This output would typically be used for such items as radio memory backups or tracker equipment. The bypass output is rated to provide 35 amps but it is not recommended to use such high current for several reasons.

Firstly the whole purpose of PowerGuard is to retain sufficient power in the battery for engine starting. All equipment connected to the bypass output will continue to drain the battery. For this reason only connect equipment that **MUST** have a permanent feed. A list of “**MUST**” have equipment would typically be the radio memory backup, clock and alarm/immobiliser.

Secondly (and perhaps more importantly) higher current draw from this terminal would require heavier gauge wire to be used in the installation of PowerGuard in order to ensure correct and reliable operation.

PowerGuard should be installed by reference to the wiring diagram in conjunction with the following notes.

1. 1.5mm² cable should be used for all interconnections between the PowerGuard control unit, the reset switch and the relay.
2. The fuse in the power feed to PowerGuard should be a 5 amp fuse fitted as close to the battery as possible.

WARNING All connections must be soundly and solidly made using the correct crimping tool for the spade connectors (or soldered joints). Any form of bad or loose connection could conceivably result in the engine shutting down whilst driving or other malfunctions

3. In the UK a legal requirement is that the hazard warning lights must have power available at all times. For this reason they should be powered directly from the battery side of the disconnect relay via their own fuse. The fuse should be of the same rating that the vehicle currently uses in the fuse box and the cable must be of at least the same gauge as that in the wiring harness. For installation in vehicles in other countries the installer should check the relevant legislation. If in doubt, err on the side of caution and ensure a permanent feed is available to the hazard warning lights.
4. The reset switch should be fitted in a prominent position within the vehicle cabin where the LED can clearly be seen from the driving position.

- Ensure the connections to the relay coil are the correct way round ! Failure to ensure this will result in the relay having exactly the opposite action to that required. The terminal marked 'REL -' on the PCB should be connected to the unmarked coil contact on the relay. The terminal marked 'REL+' on the PCB should be connected to the coil contact marked with a '+' on the relay.

WARNING Incorrect connections to any of the terminals may cause permanent damage to the unit which will not be covered under warranty.

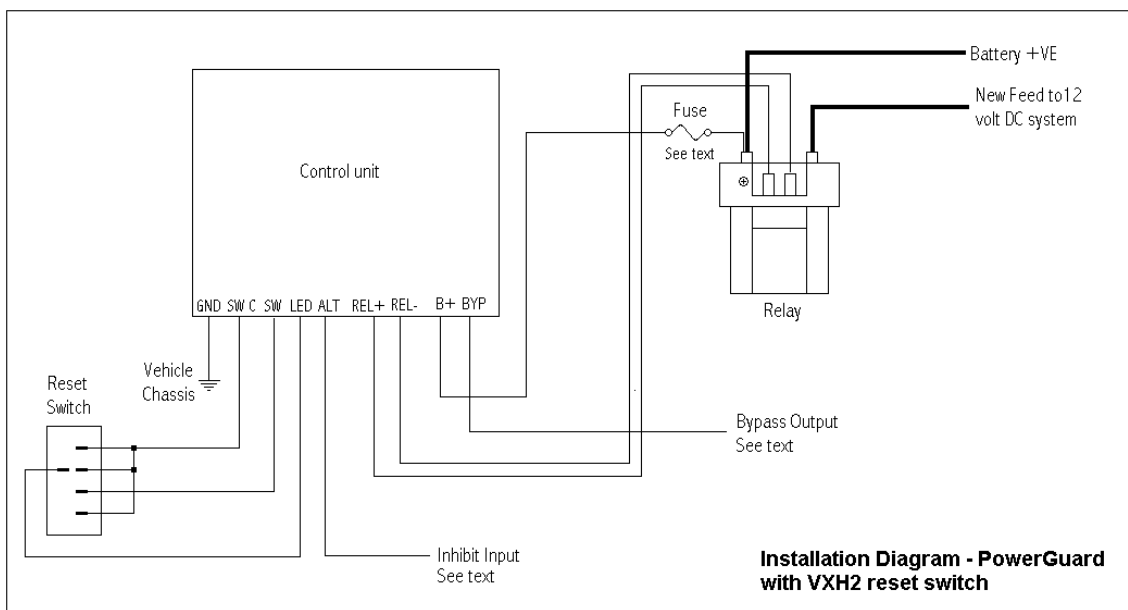
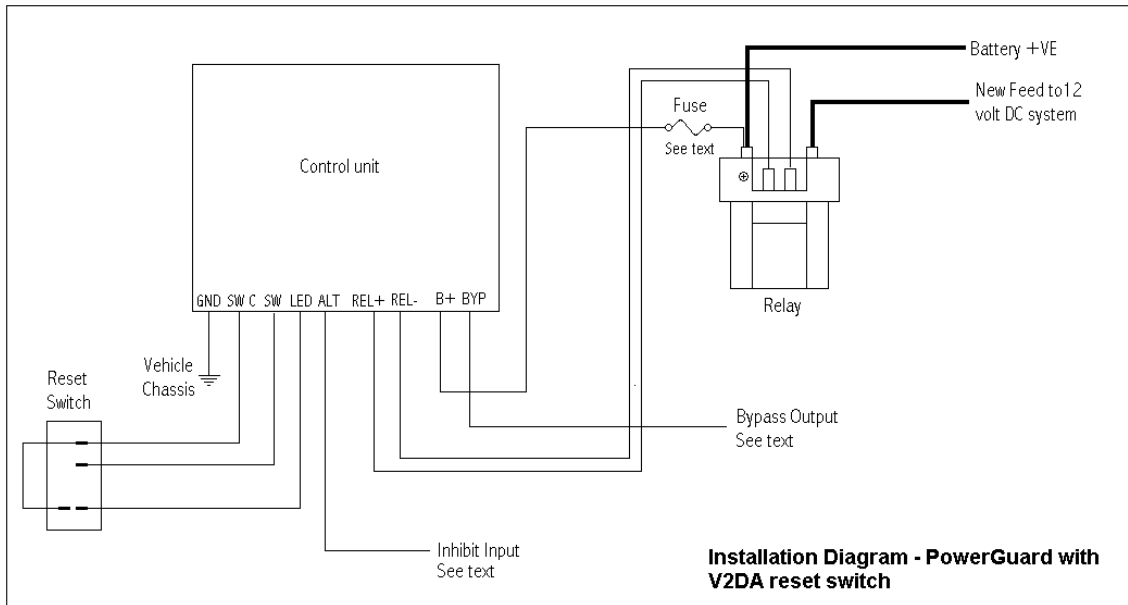

Specifications.

Current consumption:-

Standby	< 0.2mA (< 200uA)
Relay actuation	< 3 Amps
Shutdown	< 12mA
Normal voltage operation range	10 to 16 volts

[021212]